

FIRST  
IN CLEAN  
AIR

PURAFIL

# SERVICE GUIDE

# 4

## ESD DEEP BED SCRUBBER

INSTALLATION, OPERATION & MAINTENANCE  
INSTRUCTIONS

**TO BE USED IN CONJUNCTION WITH:**

SERVICE GUIDE 4 Gage Unit

SERVICE GUIDE 4 Blower Assembly

## **TABLE OF CONTENTS**

### **1.0 PRE-INSTALLATION INSTRUCTIONS**

- 1.1 Safety Considerations
- 1.2 Receiving Instructions
- 1.3 Inspection
- 1.4 Storage
- 1.5 Foundations and Clearances

### **2.0 BASIC DESIGN OF THE DBS**

### **3.0 INSTALLATION**

- 3.1 Positioning the Unit
- 3.2 Media Bank Filling (Initial Start-Up)
- 3.3 Media Bank Filling (Replacement)
- 3.4 Particulate Filters
- 3.5 Gage Unit
- 3.6 Tap Hole Location
- 3.7 Post-Start Inspection / Check

### **4.0 MAINTENANCE**

- 4.1 Replacement Parts and Materials
- 4.2 Media Replacement
- 4.3 Special Precautions
- 4.4 Purafil Stain Removal

### **5.0 WARRANTY INFORMATION**

### **6.0 TROUBLE SHOOTING**

### **7.0 SAMPLING RECORD**

## **LIST OF FIGURES**

<b>FIGURE</b>	<b>TITLE</b>
1	Basic Design
2	Media Filling (Start Up)
3	Media Replacement: Vacuuming
4	Media Replacement: Shoveling
5	Sampling Procedure

## **1.0 PRE-INSTALLATION INSTRUCTIONS**

### **1.1 SAFETY CONSIDERATIONS**

- Read this Service Manual carefully. Be thoroughly familiar with the controls and the proper use of the equipment.
- This manual should be retained with the unit because it contains the information necessary for proper maintenance. There is a pocket envelope provided for this purpose. Attach it permanently to the unit.
- Keep all nuts, bolts, and screws tight to be sure the equipment is in safe working condition.

#### **CAUTION:**

- Installer should be a trained, experienced service person.
- Disconnect power supply before wiring connections are made to prevent possible electrical shock or damage to equipment.
- Check the assembly and component weights to be sure that the rigging equipment can handle them safely.
- Be sure that the unit is balanced well in the transporting device.
- Always conduct a thorough check when the installation is complete.
- Never enter an enclosed blower cabinet or reach into a housing while fan is running.
- The motors in PURAFIL® equipment get very hot. This is normal and should not be regarded as a problem with the motor. However, take special care to avoid touching the hot areas.

### **1.2 RECEIVING INSTRUCTIONS**

**Systems are normally shipped assembled and with motors mounted.** All units are attached securely to skids. It is recommended that units be left on their skids for protection and ease of handling while transporting. Straps, rigging, slings, or hooks attached to the skids may be used, with proper care. The units are well protected with triple wall board and are secured with metal bands. Forklifts may be used under the skids, but exercise caution to prevent damage.

**Upon receiving systems from Purafil, Inc., note any shipping damage, obvious or hidden, to your carrier and on your Bill of Lading. All problems should be handled between the customer and carrier except for U.P.S. shipments, which require the customer to contact Purafil, Inc. for action.**

- If the unit is to be stored before use, see Section 1.4 in this manual.
- If the unit is to be installed immediately, be sure to check Section 3.0 in this manual.
- To uncrate unit, cut metal bands and remove packaging.
- For positioning and special handling, see Section 3.1 in this manual.

### **1.3 INSPECTION**

The condition of the unit upon its arrival is critical to its proper operation. Prior to start-up, inspect the unit carefully, according to the check list below. Correct any inadequacies before start-up to prevent possible damage or inefficiency. Note, should there be any questions concerning the unit, refer to the numbers found on the unit identification plate, when contacting the PURAFIL® representative.

#### **PRE-OPERATION CHECK LIST**

<b>YES</b>	<b>NO</b>	<b>CONDITION</b>
___	___	1. Configuration and material are as specified on the sales order form.
___	___	2. Measurements fit submittal requirements
___	___	3. Parts are all present including particulate filters, media, and gage units.
___	___	4. Filter sections all fit properly
___	___	5. Latches hold securely and gaskets seal properly
___	___	6. Labels and serial numbers are present
___	___	7. Airflow direction is consistent with installation requirements (check labels attached to unit)

*Note: Checking specific points is also imperative after the unit is started up. See section 3.4 in this manual for check list.*

## **1.4 STORAGE**

The unit should be protected from weather elements during storage, especially when storage time is extensive. While indoor storage is considered best, outdoor storage can be adequate when precautions are taken:

### **OUTDOOR STORAGE PRECAUTIONS**

- Cover the equipment with a waterproof tarp. Intake and discharge openings must be well covered. (Use of black plastic as a cover may cause excessive condensation and rusting.)
- If there is the possibility of moisture collection, allow for proper drainage.
- Do not place heavy equipment on top of the unit.
- Store Purafil® media in a dry place with less than 95% relative humidity.

## **1.5 FOUNDATION AND CLEARANCES**

### **FOUNDATIONS**

Some units may require new or reinforced foundations, due to their weight. Always be sure to check that the existing foundation is adequate for the unit to be installed. Units to be used indoors require particular attention to strength of foundation. In some instances, a concrete base is best suited to the system. Concrete allows less chance for vibration than metal structures.

### **CLEARANCE**

All units should be easily accessible for the required periodic maintenance. Do not block return and discharge grilles. Sufficient minimum clearances can be recommended by the local PURAFIL® representative.

## **2.0 BASIC DESIGN OF THE DEEP BED SCRUBBER**

Designed to clean outside air only, the DBS coupled with pre- and final particulate filters contains an intake louver, blower, space for three 12" deep vertical media beds (dependent on application), housed in the user's choice of construction. Pre-engineered in a single unit, the DBS should be applied to deliver pressurization air to recycled air systems. The DBS provides for the application of Odorcarb™ II and Odormix™ SP media, and has a lower horsepower through lower pressure drop. It is ideal for retrofit in existing rooms where higher quantity of pressurization air is required.

**FIGURE 1: BASIC DESIGN**

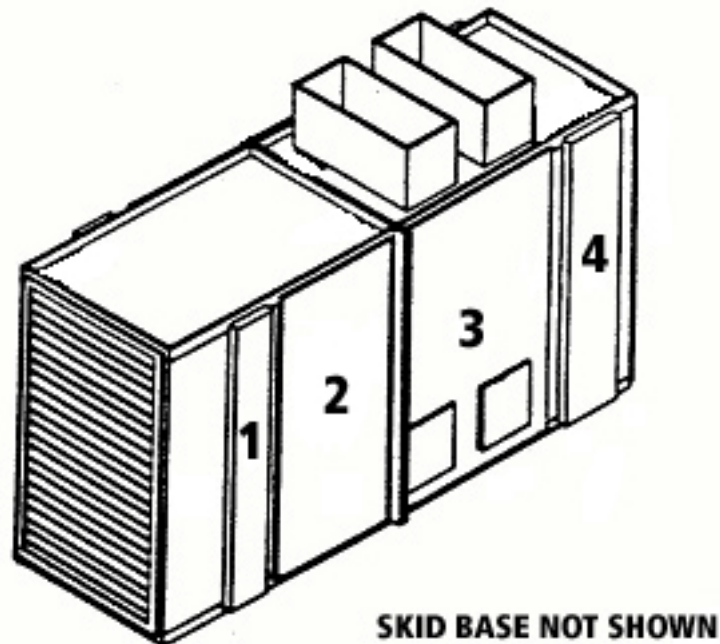

The DBS includes one or more of the following sequential components which correspond to the numbers in FIGURE 1:

1. **PREFILTER/MIST ELIMINATOR-** as the air enters the unit it passes through a particulate filter, the prefilter/mist eliminator removes mist, atmospheric dust and larger particles thereby preventing clogging of the perforated surfaces and pellet pores in the next stage of the unit.

*Prefilter options are:*

**TP-25:** A low efficiency (ASHRAE 20%) particulate filter which features include a self-sealing, progressive-density, non-woven synthetic media.

**PP-30:** A medium efficiency (MERV 6) pleated particulate filter with high surface area and good service life.

**Special Prefilters:** Special high efficiency particulate filters can be specified in prefilter section of the unit. Contact the factory or your Purafil® representative for available options.

2. **BLOWER-** the air is then drawn by the blower assembly which includes a mill and chemical duty motor, fixed V-belt drive and airfoil wheel, assuring even, quiet airflow.
3. **VERTICAL MEDIA BEDS-** the air passes through perforated PVC screens which separate the beds of Odorcarb™ II and Odormix™ SP media dependent upon the atmosphere to be controlled.
4. **FINAL FILTER-** any remaining contaminants, such as media dust and airborne contaminants are removed in this final stage particulate filter. The options for final filters are:

**JFL-90:** a high efficiency (MERV 13) rigid-type, final filter.

**PP-30:** a medium efficiency (MERV 6) pleated particulate filter with high surface area and good service life.

**FF-90:** a high efficiency (MERV 14) rigid-type particulate filter with self-supportive rigid cartridges.

**HEPA Filter:** an ultra-high efficiency (99%) particulate filter housed in a wooden frame with aluminum separators.

**Special Final Filters:** Contact your PURAFIL® representative for pricing and sizing information.

### **3.0 INSTALLATION**

After the entire pre-operative inspection is finished (Section 1.3), complete the following sequence for installation by referring to the instructions below:

- 1) Remove the unit from the skid and position it in the designated operation location
- 2) Hook up the electrical connections and check for proper rotation. (See Blower Assembly Service Guide)
- 3) Install media manufactured by Purafil, Inc. into vertical media beds. Be sure to check sales order transmittal for determining which bed will house what type of media. (See section 3.2)
- 4) Install the particulate filter. (See section 3.4)

- 5) Install and check the gage units. (See Gage Unit Service Guide and section 3.6)
- 6) Start the unit. (See section 3.7)
- 7) Perform post-start inspection check. (See section 3.7)

### **3.1 POSITIONING THE UNIT**

Review Section 1.5 in this manual for foundation and clearance instructions. Standard with each DBS unit is an all welded aluminum shipping and installation base. The base allows for the unit to be handled with ease while moving or setting in place at its predetermined job-site location. Base mounted units allow for trouble-free installation; leveling and bolt down time are reduced. The DBS is bolted to the all welded aluminum base, which would allow for easy relocation of the unit should the need arise. The standard unit can simply be lifted from its skid and “walked” or transported by lift to its pre-designated operation location (if in close proximity to the skid), according to facility safety requirements. Large units must be adequately supported to minimize racking and misalignment of doors.

### **3.2 MEDIA BANK FILLING INSTRUCTIONS (FOR INITIAL START-UP)**

Proper filling, installation, and maintenance of the chemical filtration media is critical to the unit’s efficient operation. The media banks are designed specifically for media manufactured by Purafil, Inc. and allow the system to perform to its maximum efficiency, through proper shape and bed depth.

Filling the vertical media banks is a relatively easy task, not requiring tools or specially skilled labor. Follow the steps below and repeat the process for each media bank in the unit.

- Check to determine the direction of airflow of the unit.
- Fill the vertical media beds with media manufactured by Purafil, Inc. according to the sequence prescribed on the sales order transmittal.
- To fill, pour the media through the fill funnel openings located at the top of the unit and fill the vertical media banks until the media is within 2” of the top of the fill funnel.
- Repeat this process for each vertical media bank within the unit.

**FIGURE 2: MEDIA FILLING (START UP)**

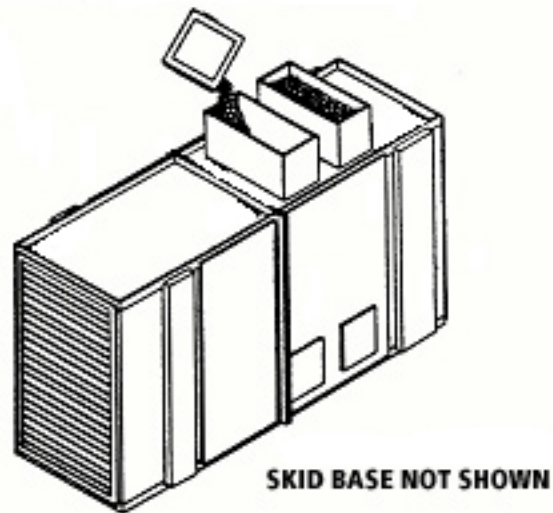

### **3.3 MEDIA BANK FILLING INSTRUCTIONS (FOR MEDIA REPLACEMENT)**

Once Purafil's Complimentary Media Life Analysis (MLA) has determined that it is time for a replacement supply of media, recharge the vertical media banks according to the instructions below: (See Section 4.2)

- Exhausted media can be exposed of by vacuuming. To vacuum the exhausted media from the unit: Use an industrial vacuum and remove the media from the bottom of the unit through the vacuum ports located in each bed. See Section 4.3 for disposal precaution of PURAFIL® media. (See Figure 4)

**FIGURE 3: MEDIA REPLACEMENT VACUUMING**

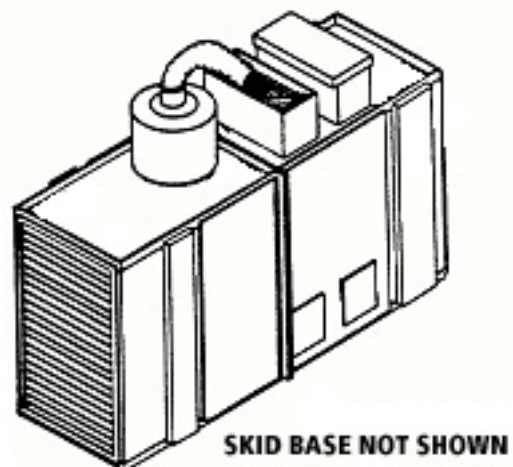

**FIGURE 4: MEDIA REPLACEMENT SHOVELING**

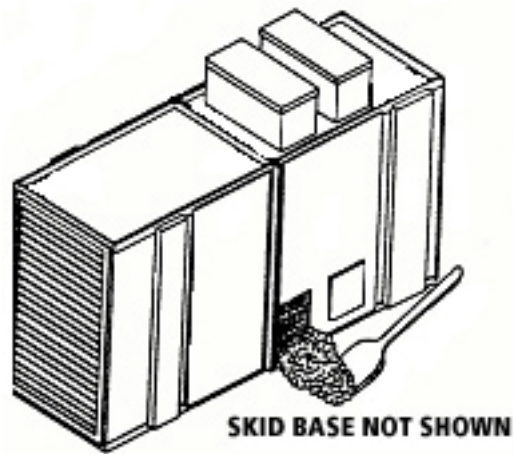

### **3.4 PARTICULATE FILTERS**

Proper selection and installation of particulate filters for use in the PURAFIL® unit will require replacement during the normal lifetime of the equipment. Replacement items may be ordered from your local PURAFIL® representative or from Purafil, Inc.

**TP-25 PREFILTER:** Install this filter by sliding it along the track so that airflow moves through the coarse white side first.

**JFL-90:** Slide the 1" header into the provided track.

**PP-30:** Install this filter by sliding it along the track until it is completely housed within the unit.

**FF-90:** Install this filter by sliding it along the track until it is completely housed within the unit.

### **3.5 GAGE UNIT**

The DBS unit is supplied with a gage unit which houses two magnehelic gages. Their purpose is to insure consistency within the recommended guidelines for airflow by reading pressure across particulate filters, thereby determining when to replace them.

As the particulate filters become soiled, pressure drop across them will increase, and the air volume actually moving through the system will decrease. Pressure drop is measured in terms of IWG. (See Gage Unit Service Guide for further information)

### 3.6 TAP HOLE LOCATIONS

There are four pressure taps on standard units. All taps should be 13/32" in diameter and have the tip of the probe pointing into or away from the direction of airflow. It is recommended that the probes are located in a straight line on the side closest to the gage unit. Air sampling ports are located on the post, before each vertical media bank. To locate your taps, follow this procedure:

- Beginning at the prefilter section, install a probe.
- The second probe is to be installed in the space after the prefilter, yet before the first vertical media bank.
- The third probe is to be installed after the last vertical media bank, yet before the final filter.
- The fourth probe is to be installed after the final filter (optional).

The top of the unit may be used for installation of probes, as well as either side of the unit.

### 3.7 POST-START INSPECTION/CHECK

Before initial start-up of system, contact your local PURAFIL® representative. After unit has been started, use the checklist below to inspect the unit is in proper working order.

YES	NO	CONDITION
___	___	1. Joints, seals, and gaskets do not leak.
___	___	2. Media has been installed properly in media beds.
___	___	3. Particulate filters have been installed.

### 4.0 MAINTENANCE

#### 4.1 REPLACEMENT PARTS AND MATERIALS

While Purafil, Inc. products are built with durability, some parts of the PURAFIL® unit will require replacement during the normal lifetime of the equipment. Replacement items may be ordered from your local PURAFIL® representative or from Purafil, Inc.

**Consumables:** In order to maintain proper performance levels, particulate filters and PURAFIL® media must be replaced periodically, as they have a finite life. (See the Media Sampling Service Guide)

**Gages:** No lubrication or periodic servicing is required. The gage unit cover and housing should be kept clean, however solvents are not recommended as a cleaning agent, as they will fog the cover. Occasionally disconnect pressure lines to vent both sides to the atmosphere; then re-zero (set) the gage. (See Gage Unit Service Guide)

**Moving Parts:** Bearings, sheaves, motors, belts, etc. are all subject to gradual deterioration and/or sudden breakdown. (See Blower Assembly Service Guide)

## **4.2 MEDIA REPLACEMENT**

PURAFIL® engineered dry-chemical media has a finite life. Our media contains special active ingredients that react with odors and gaseous pollutants to remove them from the airstream. Once the active ingredients are spent, it is time to replace the media in your system. After start-up, your local PURAFIL representative will work with the owner to periodically secure media samples. Purafil, Inc. will provide regular laboratory analysis of such samples to establish life cycles. Note, color change of media does not indicate level of remaining life.

Since every installation varies due to the type and quantity level of the contaminant, each operator must develop a sample schedule best suited to their system. However, until a schedule can be established, we recommend that a sample is taken from each vertical media bank and sent for analysis, so that a replacement date can be projected with a recommended sampling schedule.

Media Life Analysis (MLA) is a complimentary Purafil, Inc. service. MLA Sample Kits are available through Purafil, Inc. If analysis reveals that it is time to replace the media, order the appropriate pounds of media required per module used in the unit. See Media Sampling Service Guide for instructions on how to take a media sample from your unit.

## **5.0 SPECIAL PRECAUTIONS**

### **DISPOSAL**

PURAFIL® media is a non-toxic, non-flammable substance. Filtration of contaminants through PURAFIL® media causes molecular changes to occur, and the resulting product is usually not harmful to the environment. Although special precautions are generally not required when disposing of spent media, government regulations may require specific disposal procedures if the resulting

product could be harmful to the environment. Large quantities of PURAFIL® media should not be disposed of in dumpster-like equipment because the weight of the media could cause difficulties in handling the dumpster.

Independent laboratory analysis for Environmental Protection Agency toxicity characteristics may be required if the contaminants eliminated from your environment include heavy metals and pesticides.

## **INHALATION**

A well-ventilated work area is suggested for changing the PURAFIL® media, as dusting occurs in fresh media due to handling abrasion.

Workers should avoid direct inhalation of considerable PURAFIL® dust, as it induces sneezing. In closed, unventilated spaces, dust masks such as the 3-M No. 8500 are suggested.

## **WATER**

Avoid exposing the PURAFIL® media to water or precipitation, as this dissolves permanganate content. Storage of media should be in a dry place with less than 95% relative humidity. Exposure of permanganated solution to the skin causes brown staining which is temporary and not harmful. This staining can be removed by washing in a diluted solution of water and sodium bisulfite.

## **EYE CONTACT**

If dust is exposed to the eyes or delicate membrane, flush thoroughly with water and seek treatment by a physician. Follow normal procedures for exposure to abrasive dust.

## **6.0 PURAFIL® STAIN REMOVAL PROCEDURE**

The following stain removal procedure is stated here as information only, and neither Purafil, Inc., any of its subsidiaries, nor any agent or employee of Purafil, Inc. make any warranty or other representation regarding the efficacy or safety of this procedure. The stain removal could cause further damage to the garment or to the item from which one may attempt to remove the stain.

If the dust from PURAFIL® Odoroxidant™ SP\* media comes in contact with organic material, there are two possible stain problems:

1. Manganese dioxide (MnO<sub>2</sub>) which is insoluble, characterized by a medium brown color, and is found in expended PURAFIL® media, can usually be removed by normal washing.

2. New (unused) PURAFIL® Odoroxidant™ SP\* media contains sodium permanganate (NaMnO<sub>4</sub>) which is a strong oxidant and will react with and discolor any organic material with which it comes in contact. These stains, which will be brownish black in color, may be removed using a solution of sodium bisulfite in water, after the garment has been removed from the person.

However, if the fiber has been damaged by the permanganate, removal of the stain may make the damage more apparent.

CAUTION: This procedure should start with a very weak solution, gradually increasing the strength until the stain is removed. Use of too strong a solution could conceivably cause additional fabric damage.

NOTE: Sodium bisulfite gives off sulfur dioxide (SO<sub>2</sub>) gas; therefore, it must be used in a well-ventilated area.

*\*PURAFIL® Odormix™ SP media is a 50/50 water-wastewater blend of Odorkol™ media and Odoroxidant™ SP media.*

## **7.0 WARRANTY INFORMATION**

PURAFIL® warrants hardware equipment manufactured by PURAFIL® to be free from defects in material and workmanship under normal use and service for twelve (12) months from startup date or eighteen (18) months from shipment date. PURAFIL'S obligation under this warranty shall be limited to replacing any parts thereof which shall be demonstrated to have been defective. THIS WARRANTY IS EXPRESSLY IN LIEU OF ALL OTHER WARRANTIES, EXPRESS OR IMPLIED, INCLUDING THE WARRANTIES OF MERCHANTABILITY AND FITNESS.

PURAFIL MAKES NO WARRANTIES AS TO MERCHANTABILITY OR AS TO THE FITNESS OF THE MERCHANDISE FOR ANY PARTICULAR USE AND SHALL NOT BE LIABLE FOR ANY LOSS OR DAMAGE, DIRECTLY OR INDIRECTLY, ARISING FROM THE USE OF SUCH MERCHANDISE OR FOR CONSEQUENTIAL DAMAGES. No person, firm or corporation is authorized to assume for PURAFIL® any other liability in connection with the sale of these goods. Equipment, parts and material manufactured by others and incorporated in PURAFIL® equipment are warranted by PURAFIL® ONLY TO THE EXTENT OF THE ORIGINAL MANUFACTURERS LIABILITY TO PURAFIL.



Represented By:

**Important Notice**

The information contained in this bulletin reflects the results of various testing and analytical procedures believed by PURAFIL, INC. (a USA corporation) to be useful indicators of the relative performance of air filtration systems and media. It is intended for use by persons having appropriate scientific and technical knowledge and experience, at their own risk. This bulletin does not in any way constitute a representation, warranty, promise, or guarantee by PURAFIL, INC. of the installed performance of PURAFIL® media.