

FIRST  
IN CLEAN  
AIR

# SERVICE GUIDE

# 4

## BLOWER ASSEMBLY

---

INSTALLATION, OPERATION & MAINTENANCE  
INSTRUCTIONS

---

# **TABLE OF CONTENTS**

## **1.0 PRE-INSTALLATION INSTRUCTIONS**

- 1.1 SAFETY CONSIDERATIONS
- 1.2 STORAGE

## **2.0 ELECTRICAL CONNECTIONS**

## **3.0 METHOD OF INTERNAL CONNECTIONS**

## **4.0 BLOWER UNIT**

- 4.1 LUBRICATION PROCEDURE
- 4.2 BELT REPLACEMENT

## **5.0 WARRANTY INFORMATION**

## **6.0 TROUBLESHOOTING**

## **7.0 BEARINGS LUBRICATION RECORD**

### **FIGURE TITLE**

- |   |                           |
|---|---------------------------|
| 1 | FAN ROTATION DIRECTION    |
| 2 | NU-T-LINK BELT            |
| 3 | BLOWER ASSEMBLY AND PARTS |

## **1.0 PRE-INSTALLATION INSTRUCTIONS**

### **1.1 SAFETY CONSIDERATIONS**

- Read this Service Manual carefully. Be thoroughly familiar with the controls and the proper use of the equipment.
- This manual should be retained with the unit because it contains the information necessary for proper maintenance. There is a pocket envelope provided for this purpose. Attach it permanently to the unit.
- Keep all nuts, bolts, and screws tight to be sure the equipment is in safe working condition.

#### **CAUTION:**

- Installer should be a trained, experienced service person.
- Disconnect power supply before wiring connections are made to prevent possible electrical shock or damage to equipment.
- Check the equipment weights to be sure that the rigging equipment can handle them safely.
- Be sure that the unit is balanced well in the transporting device.
- Never pressurize the equipment in excess of specified test pressure.
- Always conduct a thorough check when the installation is complete.
- Never enter an enclosed blower cabinet or reach into a unit while fan is running.
- The motors in PURAFIL® equipment get very hot. This is normal and should not be regarded as a problem with the motor. However, take special care to avoid touching the hot areas.

### **1.2 STORAGE**

If the motor starter is purchased with the unit (optional) and it is to be stored with the unit, be sure to read instructions enclosed in the starter kit to prevent problems due to storage.

## 2.0 ELECTRICAL CONNECTIONS

To allow maximum flexibility in installation of the unit, no internal electrical connections or external electrical openings have been made. A qualified electrician should connect wiring from the motor to the starter and to the supply panel. All wiring and controls should comply with current NEC and local codes.

The standard unit does not have motor starter controls. Should the starter be purchased separately, the motor starter should be sized to provide proper overload protection.

## 3.0 METHOD OF INTERNAL CONNECTIONS

The motor should be wired to the power supply according to the motor manufacturers instructions. The instructions are included with the motor.

## 4.0 BLOWER UNIT

Refer to Figure 3 and the bearing discussion below for maintenance of the blower assembly.

### BEARING LUBRICATION

**IMPORTANT: READ THIS SECTION CAREFULLY!**

All bearing units are pre-lubricated with grease chosen for its chemical and mechanical stability and should be checked at least once a month. Although operating conditions vary, the optimum lubrication interval is established at every three months. Conditions such as speed, temperature, and environment may indicate shorter or longer intervals.

FIGURE 1: FAN ROTATION DIRECTION

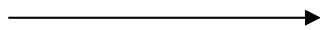
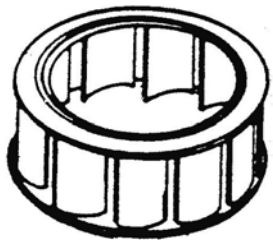

Direction of Rotation

## 4.1 LUBRICATION PROCEDURE

- 1 Every 3 months, turn unit off.
- 2 Wipe the surface of the bearings and the grease fitting clean.
- 3 While rotating the shaft by hand, gently add grease\* to the bearing until a slight bead forms at the seal.

CAUTION: DO NOT OVER-GREASE

Over-greasing will damage seals and void warranty.

- For normal operating conditions, lubrication requires a grease which conforms to NLGI No. 2 penetration, free from chemical impurities, such as dust, rust, metal particles, and abrasives. Lubrication is usually accompanied by a slight rise in operating temperature of the bearing, until the bearing chamber is stabilized with the proper amount of grease.

## 4.2 BELT REPLACEMENT

Replace the NU-T-LINK belt (Size A 1/2) by following the instructions describing the illustration below. Note, the large end of belt links should be pointed in the direction of rotation.

FIGURE 2: INSTALLATION INSTRUCTIONS FOR NU-T-LINK

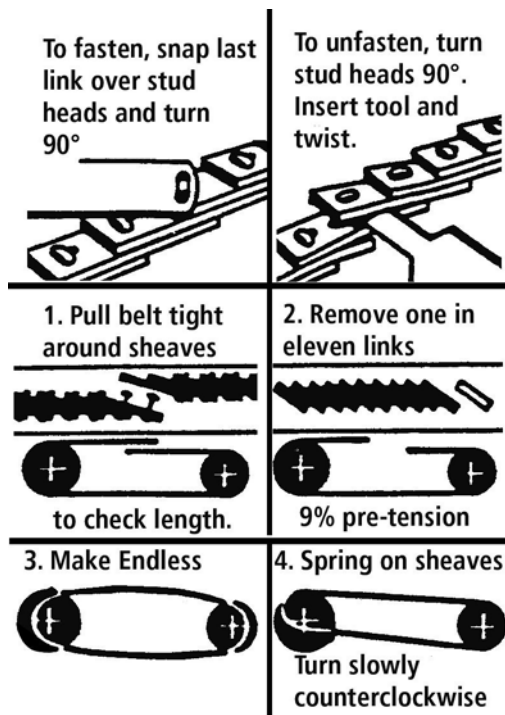
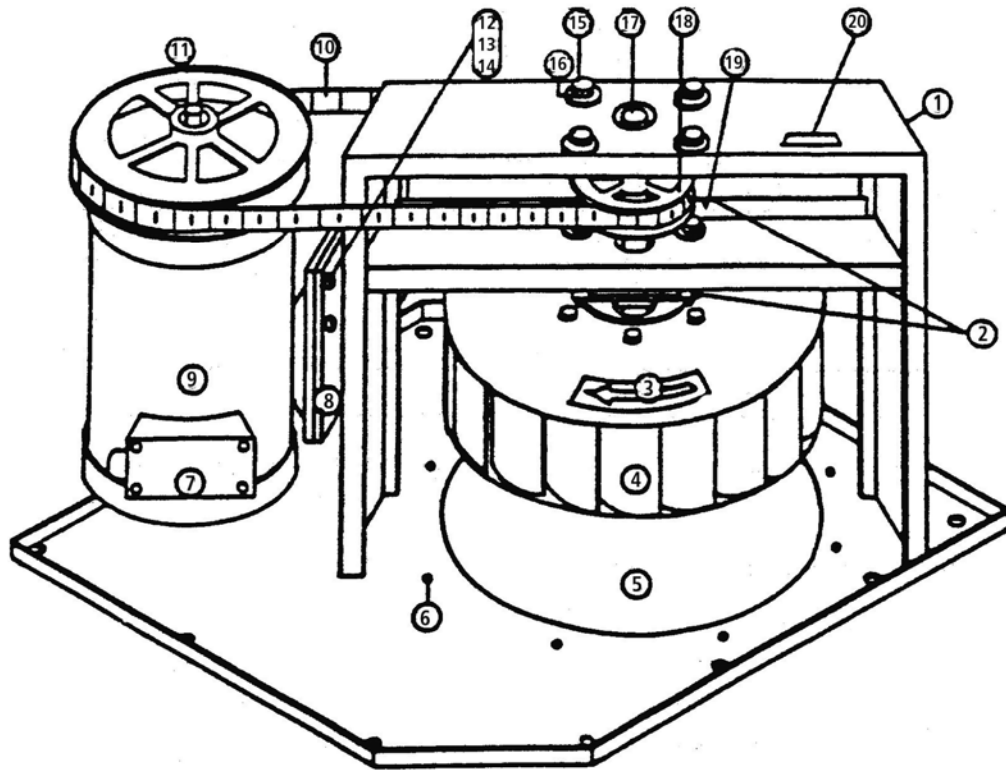

FIGURE 3: BLOWER ASSEMBLY AND PARTS LIST



Item	Description	Quantity
1	Weldment, Blower	1
2	Bearing, 1"	2
3	Label, Rotation Arrow	1
4	Wheel, Aluminum	1
5	Cone, Aluminum	1
6	Pop Rivets	10
7	Junction Box	1
8	Motor Mount	1
9	Motor	1
10	Belt, NU-T-LINK A 1/2, 44"	1
11	Sheave, Motor	1
12	Bolt, 5/16 x 1, Motor	4
13	Nut, Motor 5/16	4
14	Washer, Flat, Motor, 5/16	4
15	Bolt, 3/8 x 1-1/4	8
16	Washer, 3/8	8
17	Shaft 7 Key Assembly	1
18	Sheave, Blower	1
19	Nut, 3/8	8
20	Label, Quality Assurance	1

## **5.0 WARRANTY INFORMATION**

PURAFIL® warrants hardware equipment manufactured by PURAFIL® to be free from defects in material and workmanship under normal use and service for twelve (12) months from startup date or eighteen (18) months from shipment date. PURAFIL'S obligation under this warranty shall be limited to replacing any parts thereof which shall be demonstrated to have been defective. THIS WARRANTY IS EXPRESSLY IN LIEU OF ALL OTHER WARRANTIES, EXPRESS OR IMPLIED, INCLUDING THE WARRANTIES OF MERCHANTABILITY AND FITNESS.

PURAFIL MAKES NO WARRANTIES AS TO MERCHANTABILITY OR AS TO THE FITNESS OF THE MERCHANDISE FOR ANY PARTICULAR USE AND SHALL NOT BE LIABLE FOR ANY LOSS OR DAMAGE, DIRECTLY OR INDIRECTLY, ARISING FROM THE USE OF SUCH MERCHANDISE OR FOR CONSEQUENTIAL DAMAGES. No person, firm or corporation is authorized to assume for PURAFIL® any other liability in connection with the sale of these goods. Equipment, parts and material manufactured by others and incorporated in PURAFIL® equipment are warranted by PURAFIL® ONLY TO THE EXTENT OF THE ORIGINAL MANUFACTURERS LIABILITY TO PURAFIL.

## 6.0 TROUBLESHOOTING

<b>SYMPTOM</b>	<b>PROBLEM</b>	<b>CHECKS/REMEDY</b>
Squeal sound coming from blower section	Belt is loose (or installed backwards)	Follow instruction in Section 4.2 in this manual
Motor seems to be running too slowly	Electrical connections may be incorrect	Have an electrician compare the connections with the instructions in Section 3.0 of this manual and modify accordingly
Abnormal or excessive noise coming from the bearing housing	Lubrication may have been incorrectly done	Review bearing lubrication instructions in Section 4.1 in this manual
	Belt loose	See Section 4.2
Bearing housing seems too warm	Same as above	Same as above

Note: In the event of any abnormal condition, immediately check the electrical wiring and motor rotation direction.



Represented By:

**Important Notice**

The information contained in this bulletin reflects the results of various testing and analytical procedures believed by PURAFIL, INC. (a USA corporation) to be useful indicators of the relative performance of air filtration systems and media. It is intended for use by persons having appropriate scientific and technical knowledge and experience, at their own risk. This bulletin does not in any way constitute a representation, warranty, promise, or guarantee by PURAFIL, INC. of the installed performance of PURAFIL® media.