



FIRST
IN CLEAN
AIR

SERVICE GUIDE

For **CORROSIVE AIR UNIT**

INSTALLATION, OPERATION & MAINTENANCE
INSTRUCTIONS

TO BE USED IN CONJUNCTION WITH:

SERVICE GUIDE for Gage Unit

SERVICE GUIDE for Blower Assembly

TABLE OF CONTENTS

1.0 PRE-INSTALLATION INSTRUCTIONS

- 1.1 SAFETY CONSIDERATIONS
- 1.2 RECEIVING INSTRUCTIONS
- 1.3 INSPECTION
- 1.4 STORAGE
- 1.5 FOUNDATIONS AND CLEARANCES

2.0 OPERATIONAL CONCEPTS AND DETAILS

- 2.1 C.A. APPLICATIONS
- 2.2 HOW PURAFIL® SYSTEMS WORK
- 2.3 BASIC DESIGN OF THE C.A.
- 2.4 C.A. OPTIONS / DEFINITIONS

3.0 INSTALLATION

- 3.1 POSITIONING THE UNIT
- 3.2 MODULES
- 3.3 PARTICULATE FILTERS
- 3.4 GAGE UNIT
- 3.5 POST-START INSPECTION/CHECK

4.0 MAINTENANCE

- 4.1 REPLACEMENT PARTS AND MATERIALS
- 4.2 MEDIA REPLACEMENT
- 4.3 PURAFIL® STAIN REMOVAL

5.0 SPECIAL PRECAUTIONS

6.0 WARRANTY INFORMATION

7.0 TROUBLE SHOOTING

8.0 SAMPLING RECORD

LIST OF FIGURES

FIGURE	TITLE
1	UNIT SCHEMATIC
2	REMOVAL OF VERTICAL UNIT WITH CASTERS
3	MODULE DIRECTION FOR VERTICAL UNIT
4	MODULE DIRECTION FOR HORIZONTAL UNIT
5	MODULE LABEL
6	GAGE UNIT CONNECTIONS
7	FAN ROTATION DIRECTION
8	DATA SHEET

1.0 PRE-INSTALLATION INSTRUCTIONS

1.1 SAFETY CONSIDERATIONS

- Read this Service Manual carefully. Be thoroughly familiar with the controls and the proper use of the equipment.
- This manual should be retained with the unit because it contains the information necessary for proper maintenance. There is a pocket envelope provided for this purpose. Attach it permanently to the unit.
- Keep all nuts, bolts, and screws tight to be sure the equipment is in safe working condition.

CAUTION:

- Installer should be a trained, experienced service person.
- Disconnect power supply before wiring connections are made to prevent possible electrical shock or damage to equipment.
- Check the assembly and component weights to be sure that the rigging equipment can handle them safely.
- Be sure that the unit is balanced well in the transporting device.
- Never pressurize the equipment in excess of specified test pressure.
- Always conduct a thorough check when the installation is complete.
- Never enter an enclosed blower cabinet or reach into a housing while fan is running.
- The motors in PURAFIL[®] equipment get very hot. This is normal and should not be regarded as a problem with the motor. However, take special care to avoid touching the hot areas.

1.2 RECEIVING INSTRUCTIONS

Systems are normally shipped assembled and with motors mounted. All units are attached securely to skids. It is recommended that units be left on their skids for protection and ease of handling while transporting. Straps, rigging, slings, or hooks attached to the skids may be used, with proper care. The units are well protected with triple wall board and are secured with metal bands. Forklifts may be used under the skids, but exercise caution to prevent damage.

Upon receiving systems from Purafil, Inc., note any shipping damage, obvious or hidden, to your carrier and on your Bill of Lading. All problems should be handled between the customer and carrier except for U.P.S. shipments, which require the customer to contact Purafil, Inc. for action.

- If the unit is to be stored before use, see Section 1.4 in this manual.
- If the unit is to be installed immediately, be sure to check Section 1.5 in this manual.
- To uncrate unit, cut metal bands and remove packaging.
- For positioning and special handling, see Section 3.1 in this manual.

1.3 INSPECTION

The condition of the unit upon its arrival is critical to its proper operation. Prior to start-up, inspect the unit carefully, according to the checklist below. Correct any inadequacies before start-up to prevent possible damage or inefficiency. Note, should there be any questions concerning the unit, refer to the numbers found on the unit identification plate, when contacting the PURAFIL® representative.

PRE-OPERATION CHECK LIST

YES	NO	CONDITION
___	___	1. Configuration and material are as specified on the sales order form
___	___	2. Measurements fit submittal requirements
___	___	3. Parts are all present including modules, particulate filters, media, and gage units
___	___	4. Motor phase and voltage are correct
___	___	5. Modules, prefilter, and final filter all fit properly
___	___	6. Latches hold securely and gaskets seal properly
___	___	7. Labels and serial numbers are present
___	___	8. Airflow direction is consistent with installation requirements (check labels attached to unit)

Note: Checking specific points is also imperative after the unit is started up. See section 3.5 in this manual for checklist.

1.4 STORAGE

The unit should be protected from the elements during storage, especially when storage time is extensive. While indoor storage is considered best, outdoor storage can be adequate when precautions are taken.

OUTDOOR STORAGE PRECAUTIONS

- Cover the equipment with a tarp making sure that the bearings in the blower/motor assembly are well covered and properly ventilated, to prevent moisture condensation. Intake and discharge openings must be well covered. (Use of black plastic as a cover may cause excessive condensation and rusting.)
- If there is the possibility of moisture collection, allow for proper drainage.

INDOOR AND OUTDOOR STORAGE PRECAUTIONS

- If the unit is to be stored for an extended period of time (4-6 months or more), remove the belt from the sheaves to prevent unnecessary deformation of belting material (see Section 4.4 in this manual); rotate fans monthly to prevent bearing damage.
- If motor starter is purchased with the unit (optional) and it is to be stored with the unit, be sure to read instructions enclosed on the starter kit to prevent problems due to storage.
- Do not place heavy equipment on top of the unit.
- Store PURAFIL® media in a dry place with less than 95% relative humidity.

1.5 FOUNDATION AND CLEARANCES

FOUNDATIONS

Some units may require new or reinforced foundations, due to their weight. Always be sure to check that the existing foundation is adequate for the unit to be installed. Units to be used indoors require particular attention to strength of foundation. In some instances, a concrete base is best suited to the system. Concrete lessens the chance for vibration than if metal structures are used.

CLEARANCE

All units should be easily accessible for the required periodic maintenance. Do not block return and discharge grilles. Sufficient minimum clearances can be recommended by the local PURAFIL® representative.

2.0 OPERATIONAL CONCEPTS & DETAILS

2.1 C.A. APPLICATIONS

The Corrosive-Air™ Unit, or C.A. unit, is an air purification system which incorporates gas and particulate cleansing equipment and an integral blower section. The system is designed for the protection of electronic and electrical equipment in control rooms, computer centers, motor control centers, operator consoles, crane cabs, etc., where the environment is contaminated by corrosive gases and fumes.

2.2 HOW PURAFIL® SYSTEMS WORK

PURAFIL® corrosion control systems normally utilize two types of air cleaning units to accomplish the air quality level necessary to preclude corrosion. While the P.P.U. scrubs outside air and acts as a sacrifice and surge control filter. The second type of unit, the Corrosive-Air (C.A.), cleans recycled air. The mixed air cleaner bank design insures rapid decay of peak concentrations, and reduces the level of contamination in the room to normal; maximum operating levels. The dual system is thus capable of contaminant removal efficiencies of well above 99%. The P.P.U. can of course operate exclusive of the C.A. unit, when the room air must be exhausted, and it is called the Stand-Alone P.P.U. in this type of application. Otherwise, the P.P.U. is ducted directly to the C.A. unit.

2.3 BASIC DESIGN OF THE C.A.

The C.A. unit is self contained having particulate and gaseous contamination control capabilities. Powered with an industrial, aluminum plug blower, the C.A. unit has continuous seam welded construction and a 14 gauge steel housing. The unit is available in several horizontal and vertical configurations. The horizontal model is designed for ceiling mounting or integration into existing ductwork, while the vertical free-standing model is designed for floor location.

FIGURE 1: UNIT SCHEMATIC

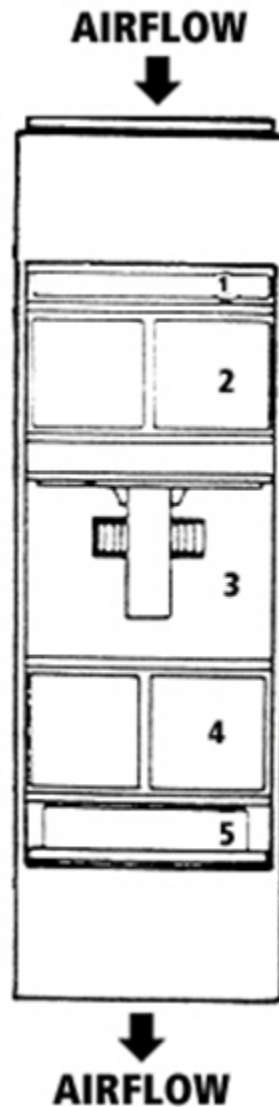

The C.A. includes one or more of the following sequential components, which correspond to the numbers in Figure 1:

1. PREFILTER—as the air enters the next section, it passes through a medium efficiency (30%), particulate filter. The filter collects atmospheric dust and larger particles, thereby preventing clogging of the perforated surfaces and pellet surface pores in the next stage of the unit.
2. PURAFIL® MODULES--the air passes through perforated, polystyrene, "V" shaped modules, which contain PURAFIL® media, which is required when the environment is laden with heavy hydrocarbons and/or chlorine compounds.
3. BLOWER--the air is then propelled further by the blower assembly, which includes a TEFC Direct Drive and airfoil wheel, assuring even, quiet airflow.

4. FINAL FILTER—before exiting the unit, the air moves through an ultra-high efficiency (90%) rigid-type, final filter. Any remaining contaminants, such as media dust and airborne contaminants are removed in this stage.
5. GAGE UNIT(S)--although not a physical part of the unit cabinet, the gage units are an integral part of the C.A.'s proper operation. These magnehelic gages are connected directly to specific pressure taps (See Gage Unit Service Guide).

2.4 C.A. OPTIONS / DEFINITIONS

Optional equipment is available to accommodate varying customer needs. These (options) may or may not be included with your unit, and are not addressed specifically in this manual. Contact the local PURAFIL® representative for further information.

- Motor starter package—includes NEMA 3R type enclosure, magnetic motor starter, and accessories
- Single phase motor
- Weatherproofing¹ (horizontal unit only)
- Insulation (horizontal unit only)
- Reverse airflow
- Tap holes for gages located on the side opposite of the door
- Casters (vertical unit only)
- Specific media as manufactured by Purafil, Inc.

Weatherproofing consists of a cross broken pan on top of the unit to shed water, with drip edges turned out over the doors to prevent direct impingement of rain on the top edge of the doors. Any screws or bolts exposed on the exterior top or sides of the unit are gasketed.

3.0 INSTALLATION

After the entire pre-operative inspection is finished (Section 1.3), complete the following sequence for installation by referring to the instructions in Section 3.1 - 3.5:

- (1) Remove the unit from the skid and position it in the designated operation location.
- (2) Hook up the electrical connections and check for proper rotation.
- (3) Fill and install the modules.
- (4) Install the particulate filter. (See section 3.3).
- (5) Install and check the gage units (See Gage Unit Service Guide).
- (6) Start the unit.
- (7) Perform post-start inspection check. (See Section 3.5)

3.1 POSITIONING THE UNIT

Review Section 1.5 in this manual for foundation and clearance instructions. The standard unit can simply be lifted from its skid and "walked" or transported by lift to its pre-designated operation location (if in close proximity to the skid), according to facility safety requirements. If the unit has casters (optional), remove it from the skid according to the following instructions and Figure 2:

FIGURE 2: REMOVAL OF VERTICAL UNIT WITH CASTERS FROM SKID

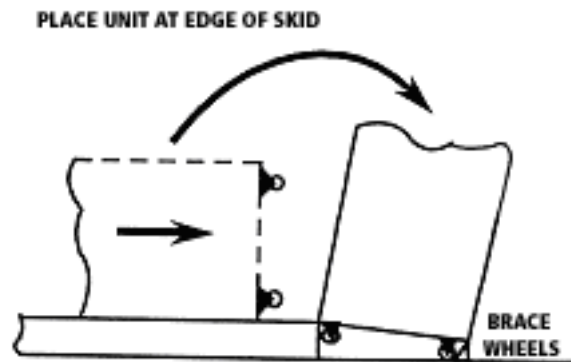

The unit is shipped lying horizontally on a skid. The unit has been arranged on the skid so that the unit can be rocked upwards on the skid edge, allowing the wheels closest to the skid to be off the floor while settling the wheels farthest from the skid on the floor. At this point, it is only necessary to remove the skid from the side of the unit and ease the second set of wheels to the floor. Note, it is suggested that you brace the wheels on the floor while easing the other wheels to the floor.

3.2 MODULES

Proper filling, installation, and maintenance of the chemical filtration media is critical to the unit's efficient operation. The modules are designed specifically for media manufactured by Purafil, Inc. and allow the media to perform to its maximum efficiency, through proper shape and bed depth.

FIGURE 3: MODULE DIRECTION FOR VERTICAL UNIT

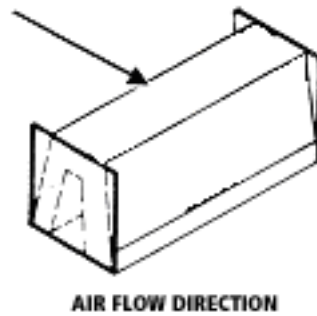

FIGURE 4: MODULE DIRECTION FOR HORIZONTAL UNIT

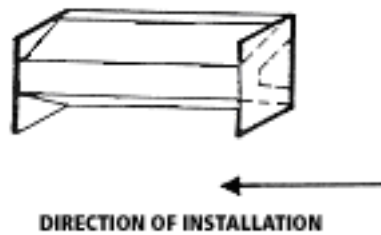
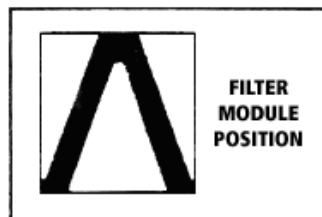

FIGURE 5: MODULE LABEL



3.3 PARTICULATE FILTERS

Proper selection and installation of particulate filters for use in PURAFIL® systems are necessary steps in obtaining the air quality best suited to the user's needs. Particulate filters are available in different sizes and efficiencies, and variations in either of these characteristics may affect the efficiency of

the PURAFIL® system. Consult filter information found in the Data Sheet of this manual for further data and projected replacement date.

TP-25 PREFILTER

Install this filter by sliding it along the track so that airflow moves through the coarse white side first.

JFL-90 FINAL FILTER

Slide the 1" header into the provided track.

3.4 GAGE UNIT

The C.A. unit is supplied with a gage unit, which houses two magnehelic gages. Their purpose is to read pressure drop across particulate filters, thereby determining when to replace them, to insure consistency within the recommended guideline for airflow. As the particulate filters become soiled, pressure drop across them is increased, and the air volume actually moving through the system is decreased. Pressure drop is measured in terms of IWG.

To insure consistency within the recommended guidelines for airflow, the particulate filters must be replaced when the appropriate terminal pressure drop is reached.

Refer to the data sheet and the Gage Unit Service Guide for further information.

FIGURE 6: GAGE UNIT CONNECTIONS

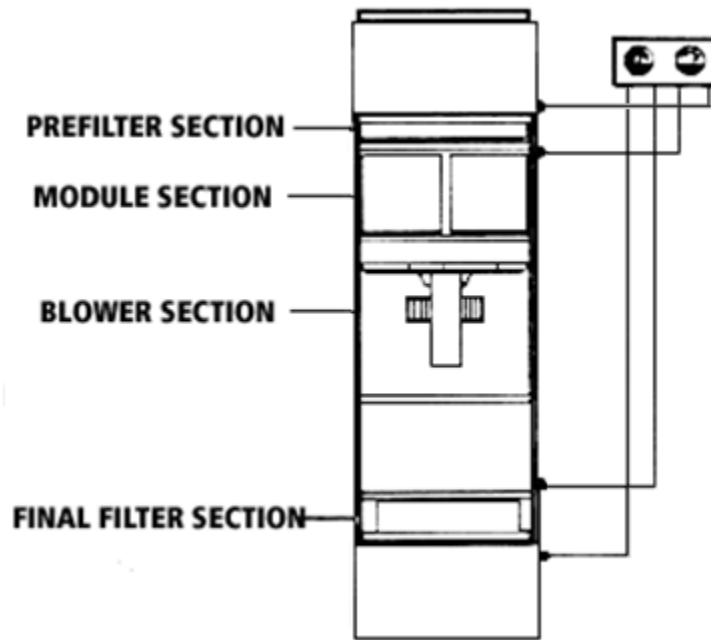

3.5 POST-START INSPECTION/CHECK

Before initial start-up of system, contact your local PURAFIL® representative. Their name and phone number is attached to your system.

YES	NO	CONDITION
___	___	1. Fan rotation is in the proper direction (See Blower Assembly Service Guide)
___	___	2. Joints, seals, and gaskets do not leak.
___	___	3. Gages work properly (i.e. lines hooked up correctly).
___	___	4. Modules are completely full of media and fit properly.
___	___	5. After 1-2 weeks of operation check belt(s) and tighten if necessary (See Blower Assembly Service Guide).

FIGURE 7: FAN ROTATION

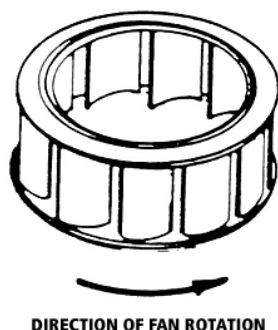

4.0 MAINTENANCE

4.1 REPLACEMENT PARTS AND MATERIALS

While Purafil, Inc. products are built for durability, some parts of the PURAFIL[®] unit will require replacement during the normal lifetime of the equipment. Replacement items may be ordered from your local PURAFIL[®] representative or from Purafil, Inc.

Certain moving parts such as motors, bearings and belts may also be obtained from conventional local sources. These items are divided into three categories.

Consumables: In order to maintain proper performance levels, particulate filters and PURAFIL[®] media must be replaced periodically, as they have a finite life (See Media Sampling Procedure Service Guide).

Gages: No lubrication or periodic servicing is required. The gage unit cover and housing should be kept clean, however, solvents are not recommended as a cleaning agent, as they will fog the cover. Occasionally disconnect pressure lines to vent both sides to the atmosphere; then re-zero (set) the gage (See Gage Unit Service Guide).

Moving Parts: Bearings, sheaves, motors, belts, etc. are all subject to gradual deterioration and/or sudden breakdown (See Blower Assembly Service Guide).

4.2 MEDIA REPLACEMENT

PURAFIL[®] engineered dry-chemical media has a finite life. Our media contains special active ingredients that react with odors and gaseous pollutants to remove them from the airstream. Once the active ingredients

are spent, it is time to replace the media in your system. After start-up, your local PURAFIL® representative will work with the owner to periodically secure media samples. Purafil, Inc. will provide regular laboratory analysis of such samples to establish life cycles. Note, color change of media does not indicate level of remaining life.

Since every installation varies due to the type and quantity level of the contaminant, each operator must develop a sample schedule best suited to their system. However, until a schedule can be established, we recommend that a sample is taken from each vertical media bank and sent for analysis, so that a replacement date can be projected with a recommended sampling schedule.

Media Life Analysis (MLA) is a complimentary Purafil, Inc. service. MLA Sample Kits are available through Purafil, Inc. If analysis reveals that it is time to replace the media, order the appropriate pounds of media required per module used in the unit. See Media Sampling Service Guide for instructions on how to take a media sample from your unit.

4.3 PURAFIL® STAIN REMOVAL

The following stain removal procedure is stated here as information only, and neither Purafil, Inc., any of its subsidiaries, nor any agent or employee of Purafil, Inc. make any warranty or other representation regarding the efficacy or safety of this procedure. The stain removal could cause further damage to the garment or to the item from which one may attempt to remove the stain.

If the dust from PURAFIL® Chemisorbant, PURAFIL® Select, or PURAFIL® SP media comes in contact with organic material, there are two possible stain problems:

1. Manganese dioxide (MnO_2) which is insoluble, characterized by a medium brown color, and is found in expended PURAFIL® media, can usually be removed by normal washing.
2. New (unused) PURAFIL® media contains potassium or sodium permanganate ($KMnO_4$ or $NaMnO_4$) which is a strong oxidant and will react with and discolor any organic material with which it comes in contact. These stains, which will be brownish black in color, may be removed using a solution of sodium bisulfite in water, after the garment has been removed from the person.

However, if the fiber has been damaged by the permanganate, removal of the stain may make the damage more apparent.

CAUTION: This procedure should start with a very weak solution, gradually increasing the strength until the stain is removed. Use of too strong a solution could conceivably cause additional fabric damage.

NOTE: Sodium bisulfite gives off sulfur dioxide (SO₂) gas; therefore, it must be used in a well-ventilated area.

5.0 SPECIAL PRECAUTIONS

Disposal

PURAFIL[®] media is a non-toxic, non-flammable substance. Filtration of contaminants through PURAFIL[®] media causes molecular changes to occur, and the resulting product is usually not harmful to the environment. Although special precautions are generally not required when disposing of spent media, government regulations may require specific disposal procedures if the resulting product could be harmful to the environment. Large quantities of PURAFIL[®] media should not be disposed of in dumpster-like equipment because the weight of the media could cause difficulties in handling the dumpster.

Independent laboratory analysis for Environmental Protection Agency toxicity characteristics may be required if the contaminants eliminated from your environment include heavy metals and pesticides.

Inhalation

A well-ventilated work area is suggested for changing the PURAFIL[®] media, as dusting occurs in fresh media due to handling abrasion. Workers should avoid direct inhalation of considerable PURAFIL[®] dust, as it induces sneezing. In closed, unventilated spaces, dust masks such as the 3-M No. 8500 are suggested.

Water

Avoid exposing the PURAFIL[®] media to water or precipitation, as this dissolves permanganate content. Storage of media should be in a dry place with less than 95% relative humidity. Exposure of permanganate solution to the skin causes brown staining which is temporary and not harmful. This staining can be removed by washing in a diluted solution of water and sodium bisulfite.

Eye Contact

If dust is exposed to the eyes or delicate membrane, flush thoroughly with water and seek treatment by a physician. Follow normal procedures for exposure to abrasive dust.

*Additional information is provided in the Purafil Material Safety Data Sheet.

Represented By:

Important Notice

The information contained in this bulletin reflects the results of various testing and analytical procedures believed by PURAFIL, INC. (a USA corporation) to be useful indicators of the relative performance of air filtration systems and media. It is intended for use by persons having appropriate scientific and technical knowledge and experience, at their own risk. This bulletin does not in any way constitute a representation, warranty, promise, or guarantee by PURAFIL, INC. of the installed performance of PURAFIL® media.